

12-1/4" x 3-1/2" Electric Wheel Brake

A-251
819-0209

Replacement Instructions



This manual is designed to provide step by step instructions for brake component replacement. Examine the brake carefully during disassembly to check for worn components and unusual wear patterns. Any worn parts should be replaced to assure normal, safe performance. Repair parts to be used for servicing the 12-1/4" x 3-1/2" brake are packaged in kits at the factory. Each kit supplies components to service a specific portion around this kit concept. Call Warner Electric at 800-234-3369 or www.warnerelectric.com for a complete list of Warner Electric authorized distributors.

⚠ WARNING Failure to follow these instructions may result in product damage, equipment damage, and serious or fatal injury to personnel.

Contents

Exploded View2
 Replacement Parts List3
 Replacement Parts Instructions
 Replacement Magnet4
 Case I5
 Case II6
 Case III8
 Replacing Shoes & Linings/
 Shoe Hold Down Springs10
 Replacing Adjuster/Adjuster Spring13
 Replacing Shoe Return Springs15
 Replacing Lever Arm Assembly
 Case I16
 Case II20
 Replacing Terminal Assembly22
 Replacing Armature23
 Replacing Shoe Hold Down
 Spring Assemblies23
 Replacing Mounting Accessories25
 Road Test and Burnish Procedure25
 WarrantyBack Cover

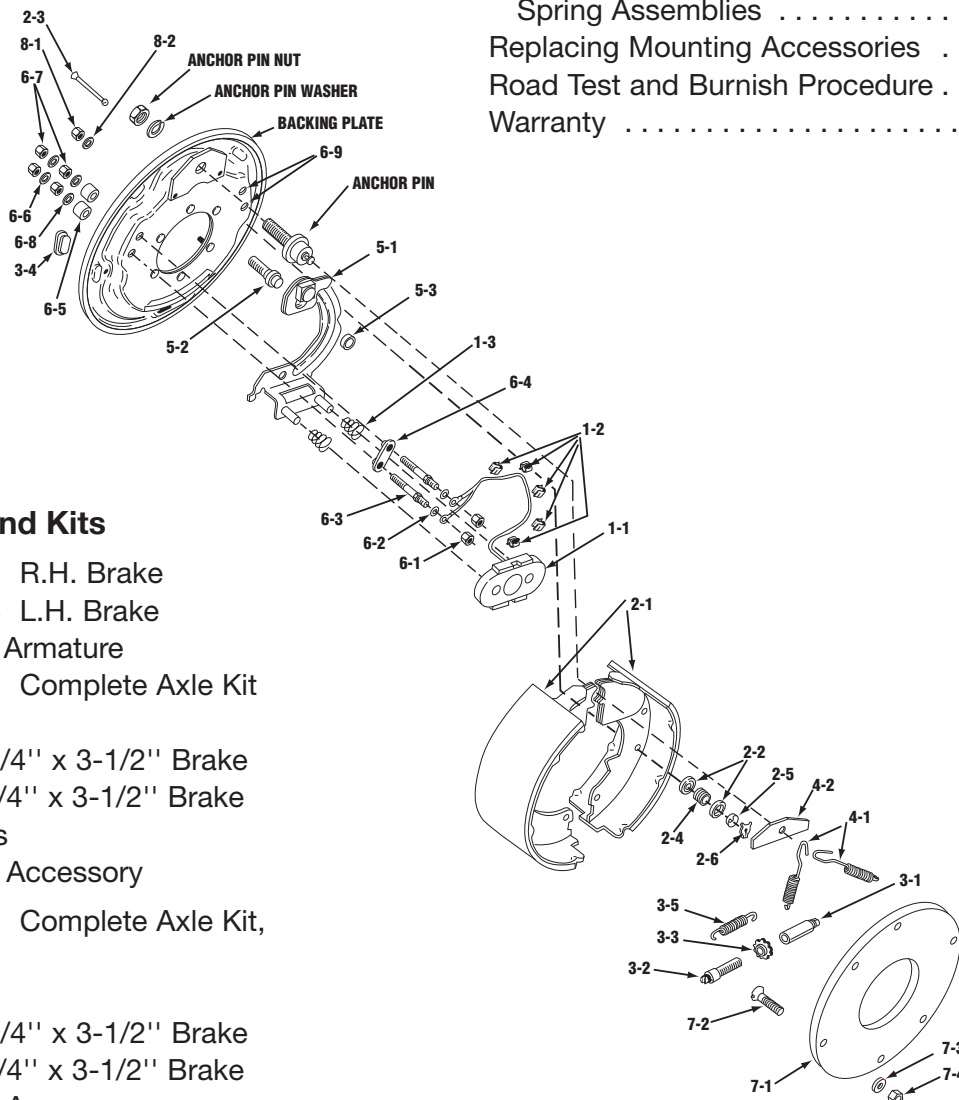

Service Parts and Kits

Kit No. 1301-12 R.H. Brake

Kit No. 1301-13 L.H. Brake

Kit No. 1301-9 Armature

Kit No. 1301-10 Complete Axle Kit

Kit consists of:

- 1 – R.H. 12-1/4" x 3-1/2" Brake
- 1 – L.H. 12-1/4" x 3-1/2" Brake
- 2 – Armatures
- 1 – Mounting Accessory

Kit No. 1301-11 Complete Axle Kit,
 Less Armatures

Kit consists of:

- 1 – R.H. 12-1/4" x 3-1/2" Brake
- 1 – L.H. 12-1/4" x 3-1/2" Brake
- 1 – Mounting Accessory

Replacement Parts

Item No.	Description	Part No.	Kit Consists of:	No. of Brakes Serviced
1	Magnet Kit	1301-100-014	1-Magnet	1
1-1	Magnet			
1-2	Wire Retaining Clips		5-Wire Retaining Clips	
1-3	Magnet Spring		2-Springs	
2-6	"X" Washer Retainer		2-"X" Washer Retainers	
2	Shoe and Lining/Shoe Hold Down Spring Kit	1301-100-005		1
2-1	Shoe Assembly		2-Shoe Assemblies	
2-2	Hold Down Spring Cup		2-Hold Down Springs	
2-3	Hold Down Pin		2-Hold Own Pins	
2-4	Hold Down Springs		4-Hold Down Spring Cups	
2-5	Spherical Washer		2-Spherical Washers	
2-6	"X" Washer Retainer		2-"X" Washer Retainers	
3	Adjuster/Adjuster Spring Kit	1301-100-006	1-Adjuster Assembly	1
3-1	Adjuster Sleeve		1-Adjuster Plug	
3-2	Screw		1-Adjuster Spring	
3-3	Nut		2-"X" Washer Retainers	
3-4	Adjuster Plug			
3-5	Adjuster Spring			
2-6	"X" Washer Retainer			
4	Shoe Return Spring Kit	1301-100-008	2-Shoe Return Springs	1
4-1	Shoe Return Spring		1-Anchor Pin Plate	
4-2	Anchor Pin Plate		2-"X" Washer Retainers	
2-6	"X" Washer Retainer			
5	Lever Arm, R.H. or Lever Arm, L.H.	1301-100-015 1301-100-016	1-Lever Arm	
5-1	Lever Arm		1-Pivot Screw	
5-2	Pivot Screw		1-Pivot Bearing	
5-3	Pivot Bearing		2-"X" Washer Retainers	
2-6	"X" Washer Retainer			
6	Terminal Assembly	1301-100-011	2-Internal Nuts	1
6-1	Internal Nut		2-Internal Washers	
6-2	Internal Washer		2-Terminal Posts	
6-3	Terminal Post		1-Terminal	
6-4	Terminal		2-Insulators	
6-5	Insulators		4-External Washers	
6-6	External Washers		4-External Nuts	
6-7	External Nut		2-Flat Washers	
6-8	Flat Washer		2-Hole Plugs	
6-9	Hole Plug		2-"X" Washer Retainers	
2-6	"X" Washer Retainer			
7	Armature Kit	1301-100-013	2-Armature Plates	2
7-1	Armature Plate		12-Screws	
7-2	Screw		12-Lockwashers	
7-3	Lockwasher		24-Nuts	
7-4	Nut		2-"X" Washer Retainers	
2-6	"X" Washer Retainers			
8	Mounting Accessory	1301-100-003	12-Nuts	2
8-1	Nuts		12-Washers	
8-2	Washers			
9	Shoe Hold Down Spring Kit	1301-100-007		1
2-2	Hold Down Springs		2-Hold Down Springs	
2-3	Hold Down Pin		2-Hold Down Pins	
2-4	Hold Down Spring Cup		4-Hold Down Spring Cups	
2-5	Spherical Washer		2-Spherical Washers	
2-6	"X" Washer Retainer		2-"X" Washer Retainers	

Parts Replacement Instructions

For ease of service, remove the brake from the axle prior to disassembly. To replace a particular kit, disassemble the brake only to the level at which the new kit items can be installed, and then reassemble. Refer to the exploded view on page 2 to identify the reference numbers in the text.

Replacing The Magnet

Kit No. 1301-100-014

See Page 3 for kit description

General Instructions

1. Refer to Figures 1 and 2 to determine which style magnets your brakes are now equipped with.



Figure 1 - New-style Long-life magnet



Figure 2 - Old-Style Dual magnets

2. Refer to Figures 3 and 4 to determine which style magnet arm your brakes are now equipped with.



Figure 3 - New Lever Arm



Figure 4 - Old Lever Arm

3. Refer to the proper instructions in the manual regarding the specific replacement of parts.

Note: New style, single, long-life magnet can be used with either the old or new arm. Old style, dual magnets will work only with old style magnet arm. Do not use dual magnets with new style magnet arm.

Note: Wire guide spring is used only when replacing single magnet on old style magnet lever arm. (Figure 5).



Figure 5 - Wire Guide Spring

Brakes must be road tested and new magnet(s) must be burnished after installation. See "Road Test and Burnish Procedure," page 25.

Case I: Replacing Single Magnet on New Style Magnet Arm with New Single Magnet

1. Remove the two shoe return springs (4-1), using a brake spring tool. (See Figure 6).



Figure 6 - Removing Shoe Return Springs

2. Remove the anchor pin plate (4-2) and spread the shoe (2-1) apart, exposing the brake terminal (6).
3. Remove the two internal nuts (6-1) which secure the magnet lead wires to the terminal posts (6-3). (See Figure 7).



Figure 7 - Removing Internal Nuts

4. Note wire routing on magnet lever arm (5-1). Mark the exact position of the wire clips (1-2) with a grease pencil, and remove the lead wires from the clips on the arm. Leave the clips in place.

5. Remove the used magnet (1-1) from the lever arm (5-1) and discard magnet.
6. Replace the used magnet springs (1-3) with new ones provided. Note small diameter end of springs set on the magnet lever arm (5-1).
7. With the magnet lever arm (5-1) positioned so the square cam is away from you, install the new single magnet on the pins so that the wires are located at the upper right hand side of the magnet. (The label on the new magnet also explains the magnet mounting method).
8. Replace the five old wire clips (1-2) on the magnet lever arm (5-1) with new clips. Install the clips in the same location as marked during disassembly (Step 4).

Route the magnet lead wires individually through the five clips on the arm, duplicating the routing noted in Step 4. (See Figure 8).



Figure 8 - Wire Routing and Magnet Position

On right-hand brakes allow 2-3/8-inches of wire between the magnet and the first clip. (See Figure 9).

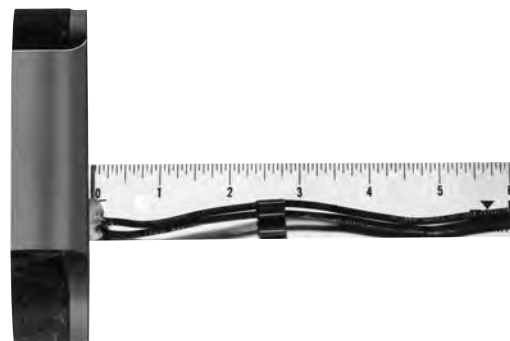

Figure 9 - R.H. Brakes

On-left hand brakes allow 3-1/8-inches of wire between the magnet and first clip. (See Figure 10).



Figure 10 - L.H. Brakes

Allowing this much wire prevents strain on the wire when the magnet is pulled out the maximum distance.

9. Assemble the magnet lead wire terminals onto the terminal posts (6-3) in the following sequence.
 - a. Place one internal lockwasher over each post.
 - b. Place one wire terminal over each post.
 - c. Place one internal nut (6-1) over each post and tighten them to 30-40 in. lb. torque.
10. Close the shoe (2-1) that was spread to expose the terminal, and install the anchor pin plate (4-2).
11. Install the shoe return springs (4-1) using a brake spring tool.
12. Check to be sure shoes expand and contract properly and are in correct adjustment.
13. Reassemble the drum and wheel. Make sure wheel bearings and wheel nuts are adjusted to axle manufacturer's specifications.

Case II: Replacing Long-Life Magnet on Old Style Arm with New Long-Life Magnet

1. Remove the two shoe return springs (4-1), using a brake spring tool. (See Figure 11).



Figure 11 - Removing Shoe Return Springs

2. Remove the anchor pin plate (4-2) and spread the shoe (2-1) apart, exposing the brake terminal assembly (6).
3. Remove the two internal nuts (6-1) which secure the magnet lead wires to the terminal posts (6-3). (See Figure 12).



Figure 12 - Removing Internal Nuts

4. Note the wire routing on the magnet lever arm (5-1). Mark the exact position of the wire clips (1-2) with a grease pencil and remove the lead wires from the clips on the arm. Leave the clips in place.

- Note how the wire guide spring is assembled and remove it from the magnet lever arm (5-1). (See Figure 13). Discard the spring.



Figure 13 - Wire Guide Spring

- Remove the used magnet (1-1) from the lever arm (5-1) and discard the magnet.
- Replace the used magnet springs (1-3) with the new springs provided. Note that the small diameter end of springs are set on the magnet lever arm (5-1).
- With the magnet lever arm (5-1) positioned so the square cam is away from you, install the new long-life magnet on the pins. The wires must be located at the upper right-hand side of the magnet.
- Install the new wire guide spring on the wires. Then installed the spring into the “V” on the magnet lever arm (5-1) exactly like the old spring was mounted. One spring end is hooked into each square tang hole in the top plate of the arm. (See Figure 14).



Figure 14 - Installing Wire Guide Spring

- Replace the five old wire clips (1-2) on the magnet lever arm (5-1) with new clips. Install the clips in the same locations as marked during the disassembly (Step 4).

Route the magnet lead wires individually through the five clips on the arm, duplicating the routing noted in Step 4 above. (See Figure 14).

On right-hand brakes allow 2-3/8-inches of wire between the magnet and first clip. (See Figure 15).

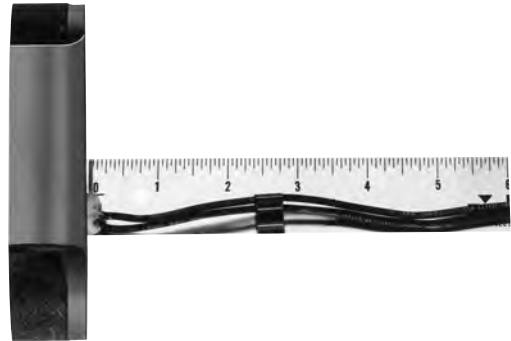

Figure 15 - R.H. Brake

On left-hand brakes allow 3-1/8-inches of wire between the magnet and first clip. (See Figure 16).



Figure 16 - L.H. Brake

Allowing this much wire prevents strain on the wire when the magnet is pulled out the maximum distance.

11. Assemble the magnet lead wire terminals onto the terminal posts (6-3) in the following sequence:
 - a. Place one internal lockwasher over each post.
 - b. Place one wire terminal over each post.
 - c. Place one internal nut over each post and tighten them to 30-40 in.-lb. torque.
12. Close the shoe (2-1) that was spread to expose the terminal and install the anchor pin plate (4-2).
13. Install the shoe return springs (4-1), using a brake spring tool.
14. Move the magnet lever arm along its track to insure that the shoes expand and contract properly and are in correct adjustment. When making this test, the shoes can stick in their expanded position. To correct this, merely push the shoe back into position. Once the shoe drum has been installed, the shoe will be restricted from expanding far enough to stick.
15. Reassemble the drum and wheel. Make sure wheel bearings and wheel nuts are adjusted to axle manufacturer's specifications.

Case III: Replacing Dual Magnets on Old Style Magnet Arm with New Single Magnet

1. Remove the two shoe return springs (4-1), using a brake spring tool. (See Figure 17).



Figure 17 - Removing Shoe Return Springs

2. Remove the anchor pin plate (4-2) and spread the shoe (2-1) apart, exposing the brake terminal assembly (6).
3. Remove the two internal nuts (6-1) which secure the magnet lead wires to the terminal posts (6-3). (See Figure 18).



Figure 18 - Removing Internal Nuts

4. Note wire routing on magnet lever arm (5-1). Mark the exact position of the wire clips (1-2) with a grease pencil, and remove the lead wires from the clips on the arm. Leave the clips in place.

- Note how the wire guide spring is assembled and remove it from the magnet lever arm (5-1). (See Figure 19). Discard the spring.



Figure 19 - Wire Guide Spring

- Remove the two used magnets from the lever arm (5-1) by pulling them off the magnet pins. Be careful not to bend the magnet arm. Discard the magnets.
- Replace the used magnet springs (1-3) with the new ones provided. Note that the small diameter end of the springs are set on the magnet lever arm (5-1).
- With the magnet lever arm (5-1) positioned so the square cam is away from you, install the new long-life magnet on the pins. The wires must be located at the upper right hand side of the magnet. (The label on the new magnet also explains the magnet mounting method).
- Install the new wire guide spring on the wires. Then install the spring into the “V” on the magnet lever arm (5-1) exactly like the old spring was mounted. One spring end is hooked into each square tang hole in the top plate of the arm. (See Figure 20).



Figure 20 - Installing Wire Guide Spring

- Replace the five old wire clips (1-2) on the magnet lever arm (5-1) with new clips. Install the clips in the same locations as marked during the disassembly (Step 4).

Route the magnet lead wires individually through the five clips on the arm, duplicating the routing noted in Step 4. (See Figure 21).



Figure 21 - Wire Routing

On right-hand brakes allow 2-3/8-inches of wire between the magnet and the first clip. (See Figure 22).

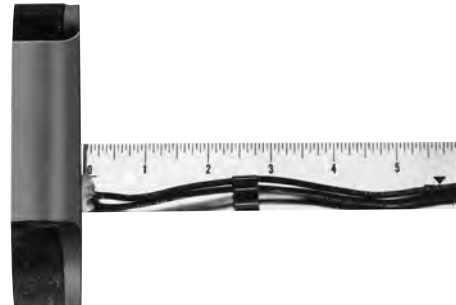

Figure 22 - R.H. Brake

On left-hand brakes allow 3-1/8-inches of wire between the magnet and the first clip. (See Figure 22 A).



Figure 22 A - L.H. Brake

Allowing this much wire prevents strain on the wires when the magnet is pulled out the maximum distance.

11. Assemble magnet lead wire terminals onto terminal posts (6-3) in the following sequence:
 - a. Place one internal lockwasher over each post.
 - b. Place one wire terminal over each post.
 - c. Place one internal nut (6-1) over each post and tighten them to 30-40 in. lbs. torque.
12. Close the shoe (2-1) that was spread to expose the terminal and install the anchor pin plate (4-2).
13. Install the shoe return springs (4-1), using a brake spring tool.
14. Move the magnet lever arm along its track to insure that the shoes expand and contract properly and are in the correct adjustment. When making this test, the shoes can stick in their expanded position. To correct this, merely push the shoe back into position. Once the shoe drum has been installed, the shoe will be restricted from expanding far enough to stick.
15. Reassemble the drum and wheel. Make sure wheel bearings and wheel nuts are adjusted to axle manufacturer's specifications.

Replacing Shoes and Linings/Shoe Hold Down Springs

Kit No. 1301-100-005

See Page 3 for kit description

Note: Shoes are interchangeable so there is no concern regarding right or left hand during assembly. Brake drums must be resurfaced or replaced when brake shoes are replaced to assure proper break-in and performance.

Brakes must be road tested and new linings worn in after installation. See "Road Test and Burnish Procedure," page 25.

1. Remove the two shoe return springs (4-1) using a brake spring tool. (See Figure 23).



Figure 23 - Removing Shoe Return Springs

2. Remove the anchor pin plate (4-2).
3. Remove the two shoe hold down spring assemblies (2-2, 2-3, 2-4, 2-5, and 2-6). There are two assembly configurations. Follow the instructions for either Style A or Style B.

⚠CAUTION These assemblies are spring loaded. Wear safety glasses while performing these operations and keep your head away from the parts being removed. Follow the instructions carefully.

Style A (old style): Style A uses a slotted, dished washer with a swaged pin to lock the spring assembly in place. (See Figure 24).



Figure 24 - Style A Shoe Hold Down Assy's

Depress the washer/spring assembly and rotate the top washer 90°.

Slowly relax the spring and disassemble.

Style B: Style B uses an "X" washer retainer (2-6) to lock the spring assembly in place. The "X" washer retainer should only be used once. If it is removed during repairs, discard it and use the new ones provided in the kit.

Depress the spring assembly and remove it, being sure to discard the old "X" washer retainer (2-6). (See Figure 25).



Figure 25 - Style B Shoe Hold Downs

4. Remove the two shoes (2-1), the adjuster (3-1, 3-2, and 3-3) and the adjuster spring (3-5) as an assembly by spreading the shoes apart at the top and lifting them off. Disassemble and discard the old shoes (2-1). Save the adjuster spring (3-5) and the adjuster (3-1, 3-2, and 3-3).

5. **Note:** This step pertains only to brakes using Style "A" shoe hold down assemblies.

Discard all old pins, rubber washers, spring cups, and old springs. Drill out the two hold down pin clearance holes in the backing plate with a 5/16-inch (.312-inch) dia. drill.

6. Lubricate the six shoe pads on the backing plate with "moly" impregnated grease. (See Figure 26).

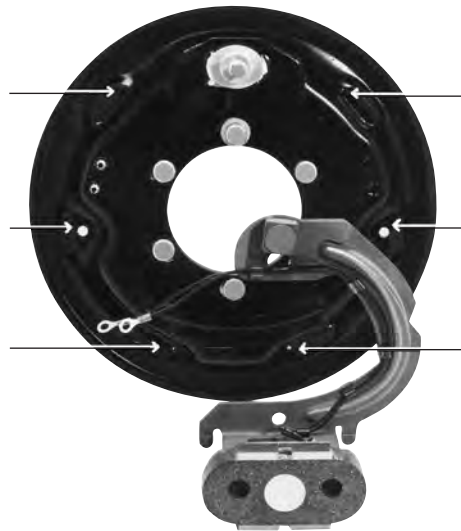

Figure 26 - Lubrication Points

7. Assemble the two new shoes (2-1), adjuster spring (3-5), and adjuster (3-1, 3-2, and 3-3). Make sure the adjuster is fitted into the notches in the shoe web. Install the assembly onto the brake. (See Figure 27).



Figure 27 - Adjuster Assembly

8. To facilitate the installation of the new style shoe hold down assemblies, rotate either shoe (2-1) away from the anchor pin so that the shoe slides off the shoe pad and onto the curl of the backing plate. This procedure will minimize the hold down spring compression required.
9. Insert a hold down pin (2-3) through the hole in the rear of the backing plate and the hole in the shoe (2-1) web. Hold pin in place.
10. Place a spring cup (2-4), convex upward, over the pin. Next install the spring (2-2), a spring cub (2-4) (convex downward), and then a spherical washer (2-5) (it nests in the spring cup) over the protruding pin (2-3).
11. Slide a new "X" washer retainer (2-6) between the head of the pin (2-3) and the spherical washer (2-5) while compressing the assembly. Using pliers, close the "X" washer retainer to lock on the pin.
12. Lift the shoe (2-1) onto the shoe pads on the backing plate with a heavy screwdriver. Rotate it into the place against the anchor pin.
13. Repeat Steps 8 through 12 for the second shoe hold down assembly.
14. Install the anchor pin plate (4-2).
15. Install the shoe return springs (4-1), using a brake spring tool.
16. Check that the shoes expand and contract properly. Set the shoes to the fully contracted position before installing the drums.
17. Reassemble the drums and wheels. Make sure the wheel bearings and wheel nuts are adjusted to the axle manufacturer's specifications.

18. Brake Adjustment: Remove the rubber adjuster plug (3-4) and insert an adjusting tool. (See Figure 28).



Figure 28 - Brake Adjustment

With the wheel off the ground, expand the shoes until the brake drags significantly. (Upward motion of the tool turns the adjusting nut, 3-3, to expand the shoes against the drum.)

Then back off the adjuster (downward motion) until the wheel turns freely, usually 10 to 12 notches.

After the initial 500 miles of operation (when the new shoes and drum have been seated), brake readjustment is recommended.

Replacing the Adjuster/Adjuster Spring

Kit No. 1301-100-006

See page 3 for kit description.

1. Remove the two shoe return springs (4-1) with a brake spring tool. (See Figure 29).



Figure 29 - Remove Shoe Return Springs

2. Remove the anchor pin plate (4-2).
3. Remove the two shoe hold down spring assemblies (2-2, 2-3, 2-4, 2-5, and 2-6). There are two assembly configurations. Follow the instructions for either Style A or Style B.

CAUTION These assemblies are spring loaded. Wear safety glasses while performing these operations, and keep your head away from the parts being removed. Follow the instructions carefully.

Style A (old style): Style A uses a slotted, dished washer with a swaged pin to lock the spring assembly in place. (See Figure 30).

Depress the washer/spring assembly and rotate the top washer 90°.



(Style A)



(Style B)

Figure 30 - Removing Shoe Hold Down Assemblies (Style A)

Slowly relax the spring and disassemble.

Style B: Style B uses an “X” washer retainer (2-6) to lock the spring assembly in place. The “X” washer retainer should only be used once. If it is removed during repairs, discard it and use the new ones provided in the kit.

Depress the spring assembly, and using a pliers, squeeze the ears of the “X” washer retainer together to open it.

Then relax the spring assembly and remove it, being sure to discard the old “X” washer retainer. (2-6). (See Figure 31).

4. Remove the two shoes (2-1), the adjuster (3-1, 3-2, and 3-3) and the adjuster spring



Figure 31 - Removing Style B Shoe Hold Down Assemblies

(3-5) as an assembly by spreading the shoes apart at the top and lifting off. Disassemble and discard the old adjuster (3-1, 3-2, and 3-3) and the old adjuster spring (3-5).

5. Lubricate the six shoe pads on the backing plate with “moly” impregnated grease. (See Figure 32).
6. Assemble the two shoes (2-1), new adjuster spring (3-5) and new adjuster (3-1, 3-2, and

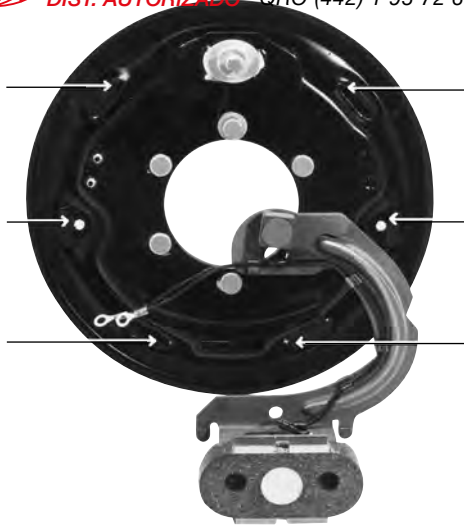

Figure 32 - Lubricating Shoe Pads

3-3). Make sure the adjuster is fitted into the notches in the shoe web. (See Figure 33).

7. Reinstall the two shoes (2-1), the adjuster

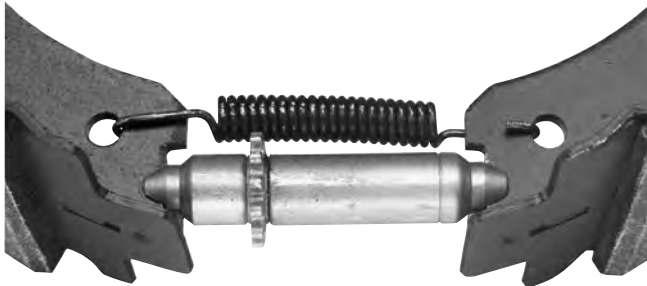

Figure 33 - Adjuster Assembly

(3-1, 3-2, and 3-3) and the adjuster spring (3-5) as a complete assembly. The adjuster nut (3-3) must be positioned over the brake adjustment access hole in the backing plate.

8. Replace the rubber adjuster plug (3-4) from the backside of the brake.
9. To facilitate the installation of the shoe hold down assemblies, rotate either shoe (2-1) away from the anchor pin so that the shoe slides off the shoe pad and onto the curl of the backing plate. This procedure will minimize the hold down spring compression required.
10. As noted in Step 3, there are two shoe hold down assembly configurations. Follow the instructions for Style A or Style B to install the shoe hold down assemblies.

Style A (old style): Insert the pin (with the

rubber washer on its head) through the rear of the backing plate and through the hole in the shoe web.

Place a dished washer, the spring, and another dished washer over the pin end.

Compress the spring assembly below the swaged end of the pin. Rotate the top washer 90° to lock the assembly into place.

Style B (new style): Insert a hold down pin (2-3) through the hole in the rear of the backing plate and through the hole in the shoe web (2-1). Hold the pin in place.

Place a spring cup (2-4), convex upward, over the pin. Next install the spring (2-2), a spring cup (2-4) convex downward, and then a spherical washer (2-5) over the protruding pin (2-3). The spherical washer nests in the spring cup.

Slide a new "X" washer retainer (2-6) between the head of the pin (2-3) and the spherical washer (2-5) while compressing the assembly. Using pliers, close the "X" retainer to lock on the pin.

11. Lift the shoe (2-1) onto the shoe pads on the backing plate with a heavy screw driver. Rotate it into place against the anchor pin.
12. Repeat steps 9 through 11 for the second shoe hold down assembly.
13. Install anchor pin plate (4-2).
14. Install shoe return springs (4-1) using a brake spring tool.
15. Check that shoes expand and contract properly and are in correct adjustment.
16. Reassemble drums and wheels. Make sure wheel bearings and wheel nuts are adjusted to axle manufacturer's specifications.
17. **Brake Adjustment**
 Remove the rubber adjuster plug (3-4), and insert an adjusting tool. (See Figure 34).

With the wheel off the ground, expand the shoes until the brake drops significantly.



Figure 34 - Brake Adjustment

(Upward motion of the tool turns the adjusting nut, 3-3, to expand the shoes against the drum).

The back off the adjuster (downward motion) until the wheel turns freely, usually 10 to 12 notches.

After the initial 500 miles of operation (when the new shoes and drum have been seated), brake readjustment is recommended.

Replacing Shoe Return Springs

Kit No. 1301-100-008

See page 3 for kit description

1. Remove the two shoe return springs (4-1) using a brake spring tool and discard them. (See Figure 35).
2. Replace the anchor pin plate (4-2) with the new one provided.
3. Install new return springs (4-1) using a brake



Figure 35 - Removing Shoe Return Springs
 spring tool.

4. Check that shoes expand and contract properly and are in correct adjustment.

Replacing Lever Arm Assembly

Kit No. 1301-100-015 (R.H.) or
 1301-100-016 (L.H.)
 See page 3 for kit description

Referring to Figures 36 and 37 determine which style magnet arm your brakes are equipped with.



Figure 36 - Old-Style Lever Arm



Figure 37 - New-Style Lever Arm

Note: The new style magnet arm will work only with the new style long-life magnet. Do not use old style, dual magnets with new style magnet arm.

Case I: Replacing Old Style Lever Arm with New Style Lever Arm

Note: Old-style dual magnets must be replaced with new style long-life magnet.

1. Remove the two shoe return springs (4-1) using a brake spring tool. (See Figure 35).
2. Remove the anchor pin plate (4-2).
3. Remove the two shoe hold down spring assemblies (2-2, 2-3, 2-4, 2-5, and 2-6). There are two assembly configurations. Follow the instructions for either Style A or Style B.

⚠CAUTION These assemblies are spring loaded. Wear safety glasses while performing these operations and keep your head away from the parts being removed. Follow instructions carefully.

Style A (old style): Style A uses a slotted, dished washer with a swaged pin to lock spring assembly in place. (See Figure 38).



(Style A)



(Style B)

Figure 38 - Removing Shoe Hold Down Assemblies (Style A)

Depress the washer/spring assembly and rotate the top washer 90°.

Slowly relax the spring and disassemble.

Style B: Style B uses an "X" washer retainer (2-6) to lock the spring assembly in place. The "X" washer retainer should only be used once. If it is removed during repairs, discard it and use the new ones provided in the kit.

Depress the spring assembly, and using a

pliers, squeeze the ears of the “X” washer retainer together to open it.

Then relax the spring assembly and remove it, being sure to discard the old “X” washer retainer (2-6). (See Figure 39).



Figure 39 - Removing Shoe Hold Down Assemblies (Style B)

4. Remove the old shoes (2-1), the adjuster (3-1, 3-2, and 3-3) and the adjuster spring (3-5) as an assembly by spreading the shoes apart at the top and lifting off.
5. Remove the two internal nuts (6-1) which secure the magnet lead wires to the terminal posts (6-3). (See Figure 40). Remove the magnet arm assembly (5-1) by pulling it straight off the pivot screw (5-2). (See Figure 41).



Figure 40 - Removing Internal Nuts



Figure 41 - Removing Magnet Arm Assembly

6. Remove the old pivot screws (5-2) from the backing plate as follows: (See Figure 42).



Figure 42 - Removing Pivot Screws

- a. Turn the backing plate over.
- b. Strike the threaded end of the screw with a hammer to drive it out.

7. Install the new pivot screw as follows:
 - a. Line up the serrations under the screw head with the grooves in the backing plate hole.
 - b. Draw the screw down with a nut and washer by tightening the nut until the screw head bottom is on the backing plate.
 - c. Remove the nut washer.
8. Note wire routing on old magnet lever arm (5-1). Remove the lead wires from the clips (1-2) on the arm, leaving the clips in place. Transfer these clips to the new lever arm, making sure they are in the same position.
9. Remove the wire guide spring from the magnet lever arm and the wires. Discard the spring. (The wire guide spring is not needed with the new style magnet lever arm.) (See Figure 43).



Figure 43 - Old Wire Guide Spring

10. Remove the magnet or magnets from the used lever arm. Install the single, long-life magnet in the same manner and location on the new arm.

11. Route the magnet lead wires individually through the five clips (1-2) on the arm. Duplicate the wiring noted in Step 8 above. (See Figure 44).



Figure 44 - Wire Routing & Magnet Position

On right-hand brakes allow 2-3/8-inches of wire between the magnet and the first clip. (See Figure 45).

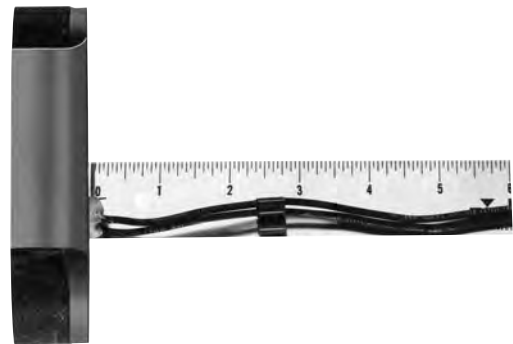

Figure 45 - R.H. Brakes

On left-hand brakes allow 3-1/8-inches of wire between magnet and the first clip. (See Figure 46).

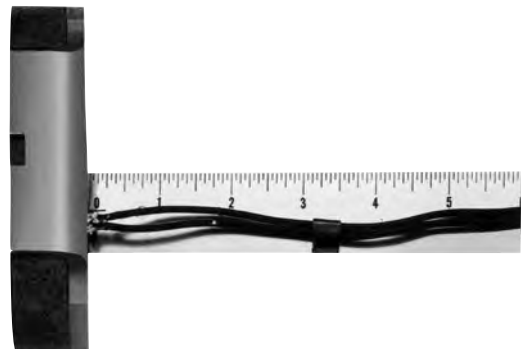

Figure 46 - L.H. Brakes

Allowing this much wire prevents strain on the wires when the magnet is pulled out the maximum distance.

12. Lubricate the following with “moly” impregnated grease:

Lever arm pivot screw (5-2).

Lever arm (5-1)–flat area around pivot screw bushing, both sides.

Lever arm “feet”, both sides (5-1).

Feet guide area of backing plate.

Six shoe pads on braking plate.

(See Figure 47) “Lubrication Points”

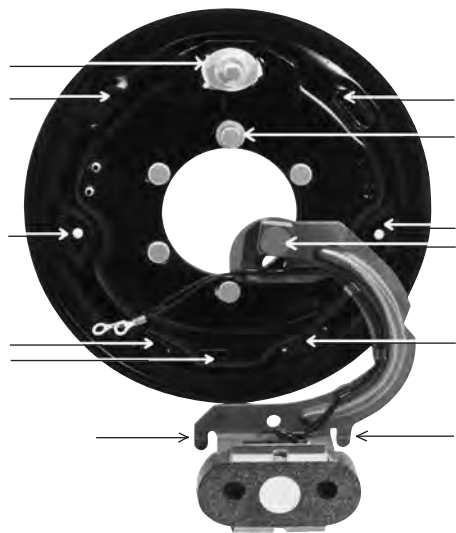

Figure 47 - Lubrication Points

13. Reassemble magnet arm (5-1) over pivot screw (5-2) making sure magnet arm “feet” slide in guide on backing plate.
14. Assemble the magnet lead wire terminals onto the terminal posts (6-3) in the following sequence.
 - a. Place one internal lockwasher over each post.
 - b. Place one wire terminal over each post.
 - c. Place one internal nut (6-1) over each post and tighten them to 30-40 in. lb. torque.

15. Reinstall the two shoes (2-1); the adjuster (3-1, 3-2, and 3-3) and the adjuster spring (3-5) as a complete assembly.
16. To facilitate the installation of the shoe hold down assemblies, rotate either shoe (2-1) away from the anchor pin so that the shoe slides off the shoe pad and onto the curl of the backing plate. This procedure will minimize the hold down spring compression required.
17. As noted in Step 3, there are two shoe hold down assembly configurations. Follow the instructions for Style A or Style B to install the shoe hold down assemblies.

Style A (old style): Insert the pin (with the rubber washer on its head) through the rear of the backing plate and through the hole in the shoe web.

Place a dished washer, the spring, and another dished washer over the pin end.

Compress the spring assembly below the swaged end of the pin. Rotate the top washer 90° to lock the assembly into place.

Repeat these steps for the second shoe hold down assembly.

Style B (new style): Insert a hold down pin (2-3) through the hole in the rear of the backing plate and through the hole in the shoe web (2-1). Hold the pin in place.

Place a spring cup (2-4), convex upward, over the pin. Next install the spring (2-2), a spring cup (2-4) convex downward, and then a spherical washer (2-5) over the protruding pin (2-3). The spherical washer nests in the spring cup.

Slide a new “X” washer retainer (2-6) between the head of the pin (2-3) and the spherical washer (2-5) while compressing the assembly. Using pliers, close the “X” retainer to lock on the pin.

Repeat these steps for the second assembly.

18. Lift the shoes (2-1) onto the shoe pads on the backing plate with a heavy screwdriver. Rotate them into place against the anchor pin.
19. Install the anchor pin plate (4-2).
20. Install the shoe return springs (4-1) using a brake spring tool.
21. Move the magnet lever arm along its track to ensure that the shoes expand and contract properly and are in the correct adjustment. When making this test, the shoes can stick in their expanded position. To correct this, merely push the shoe back into position. Once the shoe drum has been installed, the shoe will be restricted from expanding far enough to stick.
22. Reassemble the drums and wheel and make sure the wheel bearings and wheel nuts are adjusted to axle manufacturer's specifications.

Case II: Replacing New-Style Lever Arm with New-Style Lever Arm

- 1-8. Follow the instructions found for Case I, page 16.
9. Remove the magnet from the used lever arm. Install the new magnet in the same location on the new arm.
10. Route the magnet lead wires individually through the five clips (1-2) on the arm. Duplicate the wire routing noted in Step 7.

(See Figure 48).

On right-hand brakes allow 2-3/8-inches of wire between the magnet and the first clip.



Figure 48 - Wire Routing

(See Figure 49).

On left-hand brakes allow 3-1/8-inches of

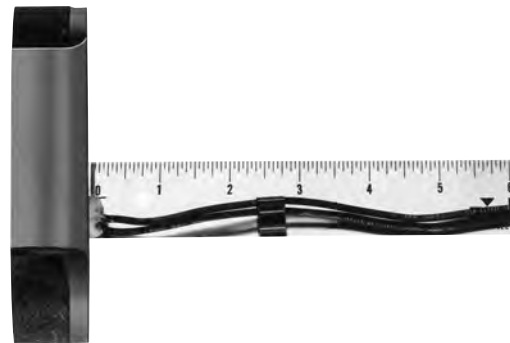

Figure 49 - R.H. Brakes

wire between the magnet and the first clip. (See Figure 50).

Allowing this much wire prevents strain on

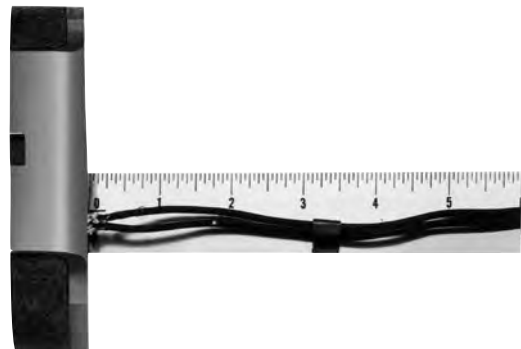

Figure 50 - L.H. Brakes

the wires when the magnet is pulled out the maximum distance.

11. Lubricate the following with “moly” impreg-

nated grease:

Lever arm pivot screw (5-2).

Lever arm (5-1)–flat area around pivot screw bushing, both sides.

Lever arm “feet”, both sides (5-1).

Feet guide area of backing plate.

Six shoe pads on backing plate.

Refer to Figure 51, “Lubrication Points.”

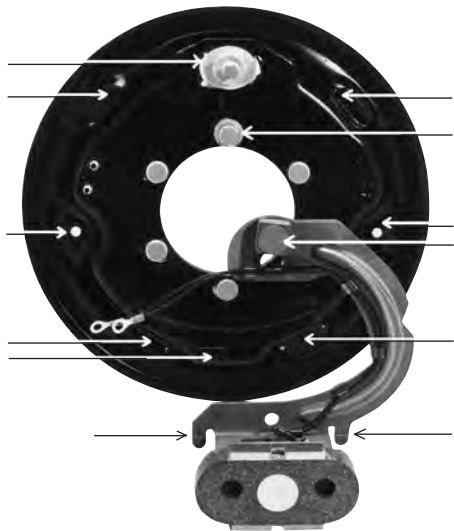

Figure 51 - Lubrication Points

12. Reassemble the magnet arm (5-1) over the pivot screw (5-2) making sure the magnet arm “feet” slide into the guide on the backing plate.
13. Assemble the magnet lead wire terminals onto the terminal posts (6-3) in the following sequence:
 - a. Place one internal lockwasher over each post.
 - b. Place one wire terminal over each post.
 - c. Place one internal nut (6-1) over each post and tighten them to 30-40 in. lbs. torque.
14. Reinstall the two shoes (2-1), the adjuster (3-1, 3-2, and 3-3) and the adjuster spring (3-5) as a complete assembly.

15. Reinstall the two shoe hold down spring assemblies. To facilitate the installation of these assemblies, rotate either shoe (2-1) away from the anchor pin so that the shoe slides off the shoe pad and onto the curl of the backing plate. This procedure will minimize the hold down spring compression required.
16. As noted in Step 3, there are two shoe hold down assembly configurations. Follow the instructions for Style A or Style B to install the shoe hold down assemblies.

Style A (old style): Insert the pin (with the rubber washer on its head) through the rear of the backing plate and through the hole in the shoe web.

Place a dished washer, the spring, and another dished washer over the pin end.

Compress the spring assembly below the swaged end of the pin. Rotate the top washer 90° to lock the assembly into place.

Repeat these steps for the second shoe hold down assembly.

Style B (new style): Insert a hold down pin (2-3) through the hole in the rear of the backing plate and through the hole in the shoe web (2-1). Hold the pin in place.

Place a spring cup (2-4), convex upward, over the pin. Next install the spring (2-2), a spring cup (2-4) convex downward, and then a spherical washer (2-5) over the protruding pin (2-3). The spherical washer nests in the spring cup.

Slide a new “X” washer retainer (2-6) between the head of the pin (2-3) and the spherical washer (2-5) while compressing the assembly. Using pliers, close the “X” retainer to lock on the pin.

Repeat these steps for second assembly.

17. Lift the shoes (2-1) onto the shoe pads on the backing plate with a heavy screwdriver. Rotate them into place against the anchor pin.

18. Install the anchor pin plate (4-2).
19. Install the shoe return springs (4-1) using a brake spring tool
20. Move the magnet lever arm along its track to ensure that the shoes expand and contract properly and are in the correct adjustment. When making this test, the shoes can stick in their expanded position. To correct this, merely push the shoe back into position. Once the shoe drum has been installed, the shoe will be restricted from expanding far enough to stick.
21. Reassemble the drums and wheel and make sure the wheel bearings and wheel nuts are adjusted to the axle manufacturer's specifications.

Replacing Terminal Assembly

Kit No. 1301-100-011

See page 3 for kit description

1. Remove the two shoe return springs (4-1) using a brake spring tool. (See Figure 52).



Figure 52 - Removing Shoe Return Springs

2. Remove the anchor pin plate (4-2) and spread the shoe (2-1) apart, exposing the brake terminal (6).
3. Remove the two internal nuts (6-1) which secure the magnet lead wires to the terminal posts (6-3). (See Figure 53).



Figure 53 - Removing Internal Nuts

4. Turn the brake over and remove the nuts (6-7), lockwashers (6-6), and flat washers (6-8) from the two terminals (6). Slide the insulators (6-5) off the terminal posts (6-3). Remove the molded plastic terminal (6-4) and posts (6-3) from the top side of the backing plate.

Install the new hardware on the backing plate in reverse order.

5. Assemble the magnet lead wire terminals onto the terminal posts (6-3) in the following sequence:

Old Style Dual Magnets

- a. Place one internal lockwasher over each post.
- b. Place two black lead wire terminals over one post.
- c. Place two white lead wire terminals over the second post.
- d. Place one internal nut (6-1) over each post and tighten them to 30-40 in. lb.

New Style Long-Life Magnet

- a. Place one internal lockwasher over each post.
 - b. Place one wire terminal over each post.
 - c. Place one internal nut (6-1) over each post and tighten them to 30-40 in. lbs. torque.
6. Close the shoe (2-1) that was spread to expose the terminal and install the anchor pin plate (4-2).
 7. Install the shoe return springs (4-1) using a brake spring tool.
 8. Remove the two old terminal hole plugs (6-9) from the backing plate and discard them. Install new hole plugs in the backing plate. Locate them in the same position, and bend their tangs to secure them in place.
 9. Check that the shoes expand and contract properly and are in correct adjustment.
 10. Reassemble the drums and wheel and make sure the wheel bearings and wheel nuts are adjusted to the axle manufacturer's specifications.

Replacing Armature

Kit No. 1301-100-013

See page 3 for kit description

1. Loosen and remove the six screws (7-2), nuts (7-4) and lockwashers (7-3) holding the armature (7-1) in place.
2. Remove the old armature (7-1) and thoroughly clean the drum interior.
3. Installed the new armature (7-1) with the hardware provided in the kit. Take care to install double jam nuts (7-4) on the armature bolts and/or peen the bolt ends to assure that the nuts do not loosen.
4. Reassemble the drum and wheel. Make sure the wheel bearing and wheel nut are adjusted to the axle manufacturer's specifications. Repeat the process for the second armature.

Replacing Shoe Hold Down Spring Assemblies

Kit No. 1301-100-007

See page 3 for kit description

Note: This kit services only brakes built after mid-1977 that use style "B" shoe hold down spring assemblies. This kit will not interchange with style "A" shoe hold down spring assemblies. Refer to "Replacing Shoes and Linings/Shoe Hold Down Springs," kit number 1301-100-005 (page 10), for a definition of the style "A" and style "B" kits and for instructions for the style "A" assemblies.

1. Remove the two shoe return springs (4-1) using a brake spring tool. (See Figure 54).
2. Remove the anchor pin plate (4-2).
3. Remove the two shoe hold down spring assemblies (2-2, 2-3, 2-4, 2-5, and 2-6).

▲CAUTION These assemblies are spring loaded. Wear safety glasses while performing these operations, and keep your head away from the parts being removed. Follow instructions carefully.



Figure 54 - Removing Shoe Return Spring

Depress the spring assembly, and using pliers, squeeze the ears of the “X” washer retainer (2-6) together to open it. Relax the spring assembly and remove it. (See Figure 55).



Figure 55 - Removing Shoe Hold Down Assemblies

Discard the old “X” washer retainer (2-6).

Repeat this procedure for the second hold down assembly.

4. To facilitate the installation of the new style shoe hold down assemblies, rotate either shoe (2-1) away from the anchor pin so that the shoe slides off the shoe pad and onto the curl of the backing plate. This procedure will minimize the hold down spring compression required.
5. Insert a hold down pin (2-3) through the hole in the rear of the backing plate and the hole in the shoe (2-1) web. Hold the pin in place.

6. Place a spring cup (2-4) convex upward, over the pin. Next install the spring (2-2), a spring cup (2-4) (convex downward), and then a spherical washer (2-5) (it nests in the spring cup) over the protruding pin (2-3).
7. Slide a new “X” washer retainer (2-6) between the head of the pin (2-3) and the spherical washer (2-5) while compressing the assembly. Using pliers, close the “X” washer retainer to lock on the pin.
8. Lift the shoe (2-1) onto the shoe pads on the backing plate with a heavy screwdriver. Rotate it into place against the anchor pin.
9. Repeat steps 4 through 8 for the second shoe hold down assembly.
10. Install the anchor pin plate (4-2).
11. Install the shoe return springs (4-1) using a brake spring tool.
12. Move the magnet lever arm along its track to ensure that the shoes expand and contract properly and are in the correct adjustment. When making this test, the shoes can stick in their expanded position. To correct this, merely push the shoe back into position. Once the shoe drum has been installed, the shoe will be restricted from expanding far enough to stick.
13. Reassemble the drums and wheels. Make sure the wheel bearings and wheel nuts are adjusted to the axle manufacturer’s specifications.

Replacing Mounting Accessories

Kit No. 1301-100-003

See Page 3 for kit description

1. Loosen and remove the six nuts (8-1) and lockwashers (8-2) holding the brake in place.
2. Reinstall the brake on its axle flange, making sure both the brake and flange are clean and free of all dirt and foreign material. Check to insure the brake is mounted properly on its pilot and rests flat against the mounting face of the axle flange.
3. Install the new nuts and washers provided in the kit. Tighten the nuts to 71 to 79 lb. ft. torque.

Road Test and Burnish Procedure

1. Check the brake system by measuring amperage at each brake. Connect an ammeter between either of the brake terminals and the wire disconnect from that terminal. The ammeter should read between 2.0–3.3 amps when brake is fully energized.
2. Make certain each brake is working mechanically by lifting the axle, spinning the wheel, and energizing the brake. The wheel should come to a rapid halt.
3. Road check the brakes by making a few low speed stops. Then burnish the brakes. A fifty (50) stop minimum burnish at the following conditions is recommended.

Stop Speed: 40 MPH – 0 MPH
Stop Accel: 12 F.P.S.P.S. (Hard Stops)
Number of Stops: 50 – 200
Road Condition: Seldom used road, straight and flat, with extended visibility.

Warranty

Warner Electric LLC warrants that it will repair or replace (whichever it deems advisable) any product manufactured and sold by it which proves to be defective in material or workmanship within a period of one (1) year from the date of original purchase for consumer, commercial or industrial use.

This warranty extends only to the original purchaser and is not transferable or assignable without Warner Electric LLC's prior consent.

Warranty service can be obtained in the U.S.A. by returning any defective product, transportation charges prepaid, to the appropriate Warner Electric LLC factory. Additional warranty information may be obtained by writing the Customer Satisfaction Department, Warner Electric LLC, 449 Gardner Street, South Beloit, Illinois 61080, or by calling 815-389-3771.

A purchase receipt or other proof of original purchase will be required before warranty service is rendered. If found defective under the terms of this warranty, repair or replacement will be made, without charge, together with a refund for transportation costs. If found not to be defective, you will be notified and, with your consent, the item will be repaired or replaced and returned to you at your expense.

This warranty covers normal use and does not cover damage or defect which results from alteration, accident, neglect, or improper installation, operation, or maintenance.

Some states do not allow limitation on how long an implied warranty lasts, so the above limitation may not apply to you.

Warner Electric LLC's obligation under this warranty is limited to the repair or replacement of the defective product and in no event shall Warner Electric LLC be liable for consequential, indirect, or incidental damages of any kind incurred by reason of the manufacture, sale or use of any defective product. Warner Electric LLC neither assumes nor authorizes any other person to give any other warranty or to assume any other obligation or liability on its behalf.

WITH RESPECT TO CONSUMER USE OF THE PRODUCT, ANY IMPLIED WARRANTIES WHICH THE CONSUMER MAY HAVE ARE LIMITED IN DURATION TO ONE YEAR FROM THE DATE OF ORIGINAL CONSUMER PURCHASE. WITH RESPECT TO COMMERCIAL AND INDUSTRIAL USES OF THE PRODUCT, THE FOREGOING WARRANTY IS IN LIEU OF AND EXCLUDES ALL OTHER WARRANTIES, WHETHER EXPRESSED OR IMPLIED BY OPERATION OF LAW OR OTHERWISE, INCLUDING, BUT NOT LIMITED TO, ANY IMPLIED WARRANTIES OF MERCHANTABILITY OR FITNESS.

Some states do not allow the exclusion or limitation of incidental or consequential damages, so the above limitation or exclusion may not apply to you. This warranty gives you specific legal rights and you may also have other rights which vary from state to state.

Changes in Dimensions and Specifications

All dimensions and specifications shown in Warner Electric catalogs are subject to change without notice. Weights do not include weight of boxing for shipment. Certified prints will be furnished without charge on request to Warner Electric.



Warner Electric LLC
449 Gardner Street • South Beloit, IL 61080
815-389-3771 • Fax: 815-389-2582
www.warnerelectric.com
An Altra Industrial Motion Company